

COLLEZIONE '26

 ITALAMP



Con 50 anni di storia nel panorama del lighting design italiano, Italamp è oggi un punto di riferimento nell'illuminazione decorativa di alta gamma. Nel tempo l'azienda ha costruito la propria riconoscibilità distinguendosi per un'offerta eclettica che spazia tra design classico e contemporaneo, arricchita anche da collaborazioni con progettisti internazionali. Tutte le collezioni sono progettate e realizzate interamente in Italia, dove la sapienza artigianale, l'innovazione tecnologica e una visione progettuale in continua evoluzione si fondono per dare forma a opere di luce esclusive, espressione concreta di ricerca, massima qualità e unicità.

With 50 years of history in the Italian lighting design landscape, Italamp is today a benchmark in high-end decorative lighting. Over time, the company has built a distinctive identity, standing out for its eclectic offering that ranges from classic to contemporary design, enriched by collaborations with international designers. All collections are entirely designed and manufactured in Italy, where artisanal expertise, technological innovation, and an ever-evolving design vision merge to create exclusive lighting pieces—tangible expressions of research, the highest quality, and uniqueness.

In occasione del Fuorisalone 2026, Itlamp presenta una selezione di nuove creazioni che riflettono l'evoluzione del suo linguaggio progettuale.

Dall'estensione di collezioni esistenti a concept completamente nuovi, ogni proposta esplora diverse espressioni della luce: composizioni modulari, finiture raffinate e forme essenziali pensate per adattarsi a una pluralità di contesti.

Queste novità delineano un racconto coerente e al tempo stesso sfaccettato, in cui la luce diventa strumento di composizione, atmosfera e personalizzazione.

At Fuorisalone 2026, Itlamp presents a selection of new creations that reflect its evolving design language.

From the extension of existing collections to entirely new concepts, each piece explores different expressions of light: modular compositions, refined finishes, and essential forms designed to adapt to a variety of interiors.

Together, these novelties outline a cohesive yet multifaceted narrative, where light becomes a tool for composition, atmosphere and personalization.

SUMMARY

8 CHEOPE

14 CLIP

20 MUNA

28 OLYMPIA

34 PALETTE



CHEOPE

design by
ROBERTA VITADELLO

Cheope introduce una nuova visione di chandelier decorativo, in cui il linguaggio classico viene reinterpretato attraverso un approccio modulare e contemporaneo.

Cheope introduces a new vision of the decorative chandelier, where classical language is reinterpreted through a modular and contemporary approach.



Gli elementi si liberano da una struttura rigida, dando vita a una composizione fluida e dinamica, capace di svilupparsi nello spazio con naturale eleganza.

Its elements are released from a rigid structure, giving shape to a fluid and dynamic composition that unfolds naturally within the space.



256 / S8

256

Nasce come chandelier singolo, ma può essere accostato ad altri moduli per creare configurazioni più ampie e scenografiche. Cheope supera così l'idea di chandelier come elemento unico, proponendo un'estetica evolutiva che unisce memoria e innovazione.

Conceived as a single chandelier, it can be combined with additional modules to create broader, more scenographic configurations. Cheope moves beyond the idea of the chandelier as a single, fixed piece, proposing an evolving aesthetic that brings together memory and innovation.



CLIP

design by **PIO&TITO TOSO**



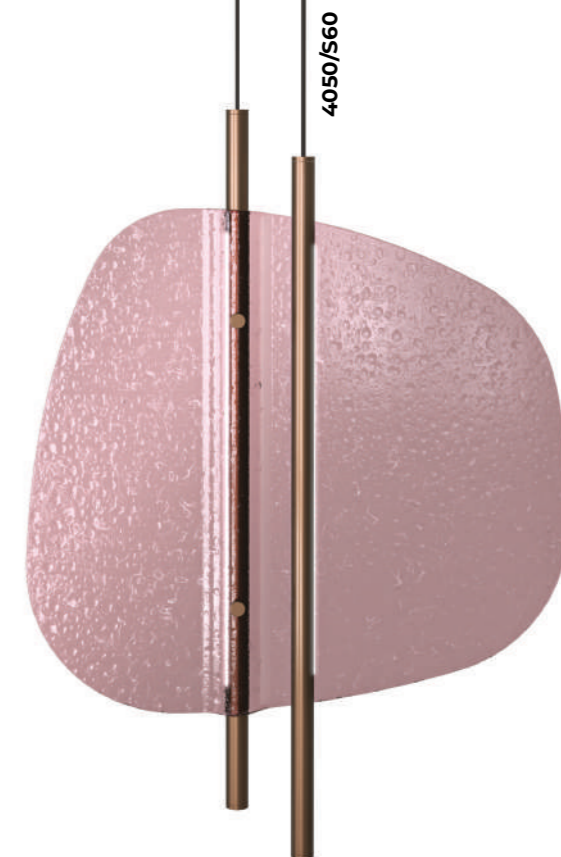
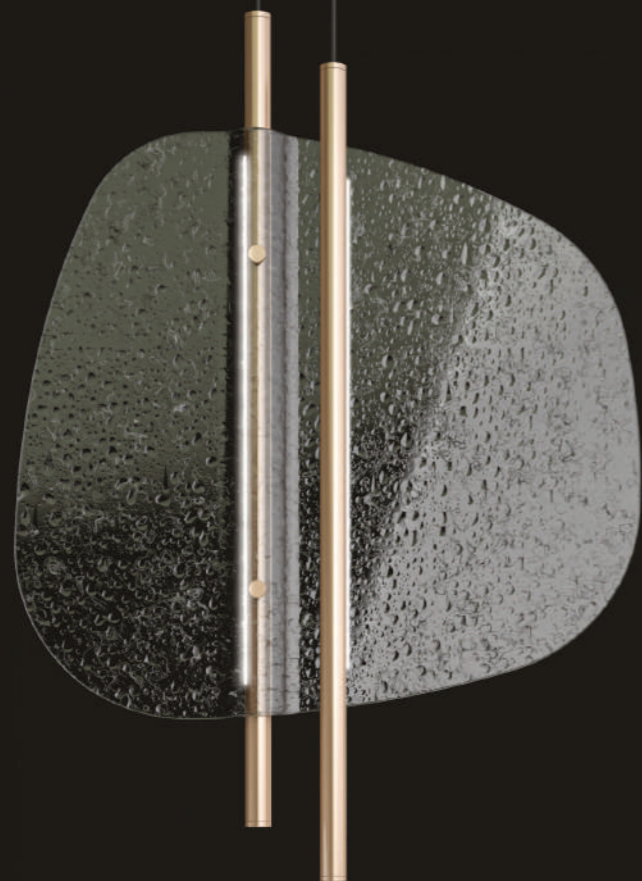

Clip sospensione nasce come evoluzione della versione wall lamp, ampliandone il linguaggio in una nuova declinazione sospesa.

Clip suspension evolves from the wall version, expanding its language into a new suspended dimension.



4050

design by **PIO&TITO TOSO**

Il progetto si sviluppa attorno all'incontro tra vetro e metallo, il diffusore accoglie e modula la luce generando riflessi morbidi e avvolgenti, mentre la struttura metallica introduce un segno deciso che definisce l'equilibrio della composizione.

The project is defined by the interaction between thermoformed glass and metal: the diffuser captures and modulates the light, creating soft and enveloping reflections, while the metal structure introduces a precise, vertical sign that balances the composition.





MUNA

design by **DANILO DE ROSSI**



Muna sospensione evolve attraverso nuove finiture mantenendo intatta la propria identità e rafforzando il suo carattere distintivo. Le varianti Tortora e Fumé introducono nuove possibilità espressive della collezione.

Muna suspension evolves through new finishes preserving its identity while enhancing its distinctive character. The Dove and Fumé versions introduce new expressive possibilities of the collection.



DANILO DE ROSSI

4030

Ispirata alle forme sospese dei corpi celesti, Muna si definisce come un volume morbido e scultoreo, in cui il vetro soffiato rigato filtra la luce con delicatezza. Il diffusore interno, con effetto lunare, genera una luminosità soffusa e avvolgente.

Inspired by the suspended forms of celestial bodies, Muna is defined as a soft, sculptural volume, where ribbed blown glass gently filters the light. The inner diffuser, with its lunar effect, creates a soft and enveloping glow.



MUNA

design by
DANILO DE ROSSI



4030 / LM



Muna si amplia con una nuova versione da tavolo, mantenendo intatta la propria identità. Il volume, ispirato alle piccole lampade portatili, si sviluppa in dimensioni più generose, trasformando la lampada in un elemento protagonista.

Muna expands with a new table version, preserving its identity. Its volume, inspired by small portable lamps, is expressed in more generous proportions, turning the piece into a defining element.

*a silent gesture
that delicately illuminates
the space*



4030 / LM

design by **DANILO DE ROSSI**

Disponibile nelle finiture Tortora, Traspirente e Fumé, Muna tavolo interpreta la luce come presenza silenziosa, capace di definire lo spazio con equilibrio e naturalezza.

Available in Tortora, Clear and Fumé finishes, Muna table interprets light as a quiet presence, capable of shaping the space with balance and naturalness.

OLYMPIA



design by **ITALAMP STUDIO**

768/100

Olympia è una sospensione dal linguaggio contemporaneo, caratterizzata da una struttura leggera e ritmica composta da elementi in vetro trasparente.

Olympia is a suspension lamp with a contemporary language, defined by a light and rhythmic structure composed of transparent glass tubes.



L'elemento distintivo è la fascia metallica centrale disponibile nella nuova finitura titanio spazzolato, che definisce il volume e introduce un segno deciso e architettonico, in equilibrio con la trasparenza del vetro.

Its defining feature is the central metal ring, which shapes the volume and introduces a strong architectural sign, in balance with the transparency of the glass.





PALETTE

design by **ITALAMP STUDIO**

Palette è il nuovo elemento della collezione Kaleido, un'installazione luminosa che esprime l'anima creativa del brand, dove la luce diventa linguaggio e materia narrativa.

Palette is the new element of the Kaleido collection, a lighting installation conceived to express the brand's creative identity, where light becomes both language and narrative material.

T785/J

Sottili elementi in vetro
si sovrappongono come pennellate
luminose, creando un equilibrio tra
delicatezza e rigore formale.

Thin glass elements
overlap like luminous brushstrokes,
creating a balance between delicacy
and formal rigor.



T785/H

T785/A





Il vetro, protagonista assoluto,
si trasforma in una superficie
vibrante, capace di catturare e
rifrangere la luce con una sensibilità
quasi pittorica.

Glass, the absolute protagonist,
becomes a vibrant surface capable
of capturing and refracting light
with an almost painterly sensitivity.

T785/D

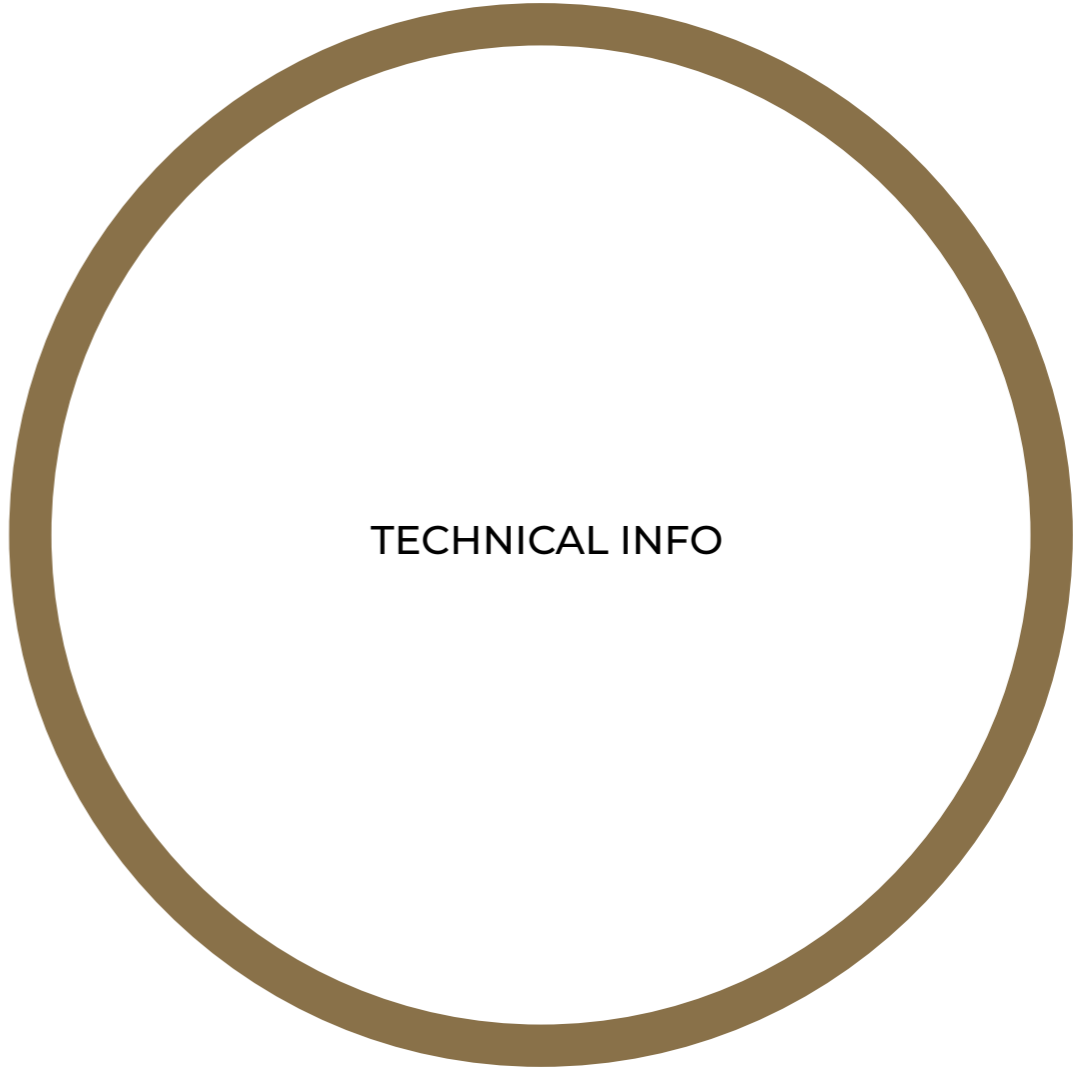

TECHNICAL INFO

CHEOPE

design by **Roberta Vitadello**

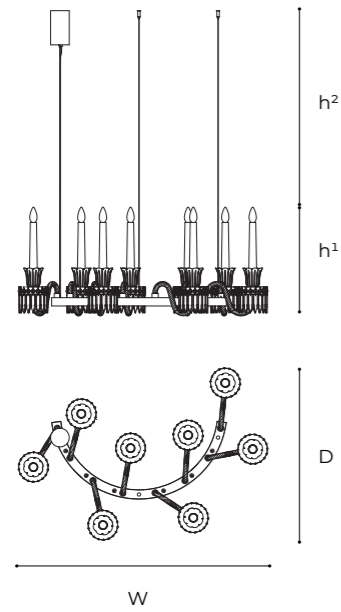

256/S8

W 120 . D 80 . h¹ 50 . h² 10-100
W 47" . D 31" . h¹ 20" . h² 4"-39"
8x6w Led - 8w - 300lm
CRI>80 - 3000K

Finishes:



Certifications:



CLIP

design by **Pio&Tito Toso**

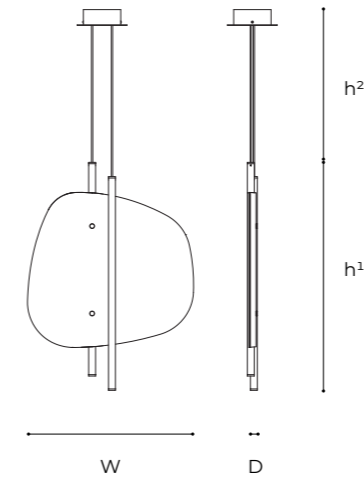

4050/S60

W 60 . D 9 . h¹ 82 . h² 10-100
Ø 24" . D 4" . h¹ 32" . h² 4"-39"
16w Led - 1200lm
CRI>90 - 3000K

Finishes:



Certifications:

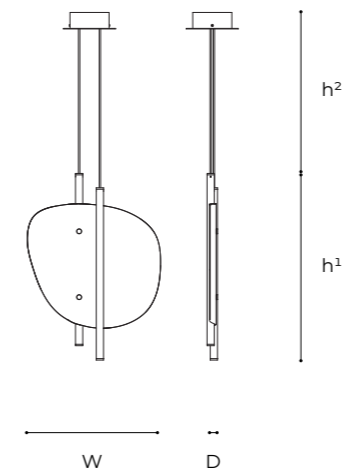

4050/S45

W 46 . D 9 . h¹ 64 . h² 10-100
W 18" . D 4" . h¹ 25" . h² 4"-39"
14w Led - 1100lm
CRI>80 - 3000K

Finishes:



Certifications:



MUNA

design by **Danilo De Rossi**

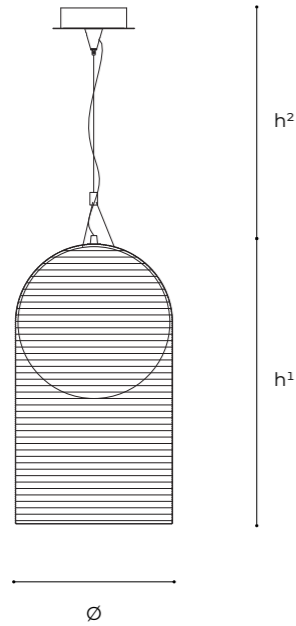

4030/SG

Ø 30 . h¹ 55 . h² 10-100
Ø 12" . h¹ 22" . h² 4"-39"
15,5w Module Led - 2000lm
CRI>80 - 3000K

Finishes:



CDF

Certifications:

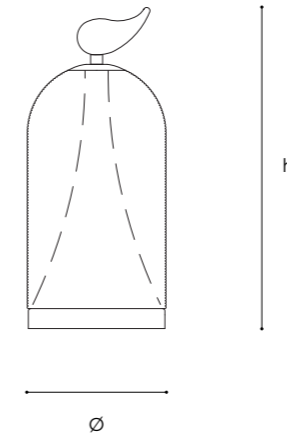

4030/LM

Ø 21 . h¹ 40
Ø 8" . h¹ 16"
7,8w Led - 1000lm
CRI>80 - 3000K

Finishes:



CDF

Certifications:

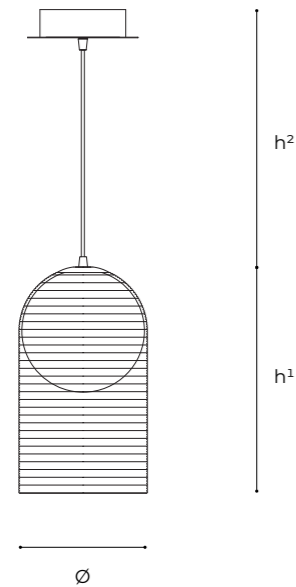

4030/SP

Ø 21 . h¹ 37 . h² 10-100
Ø 8" . D 15" . h¹ 15" . h² 4"-39"
7,8w Module Led - 1000lm
CRI>80 - 3000K

Finishes:



CDF

Certifications:



OLYMPIA

design by **Italamp Studio**

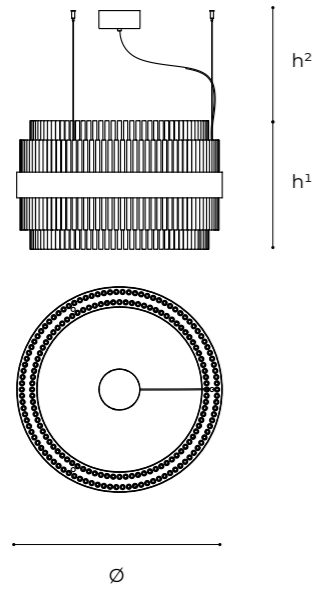

768/S80

Ø 80 . h^1 50 . h^2 10-100
 Ø 31" . h^1 20" . h^2 4"-39"
 85w Module Led - 9000lm
 CRI>90 - 3000K

Finishes:



Certifications:

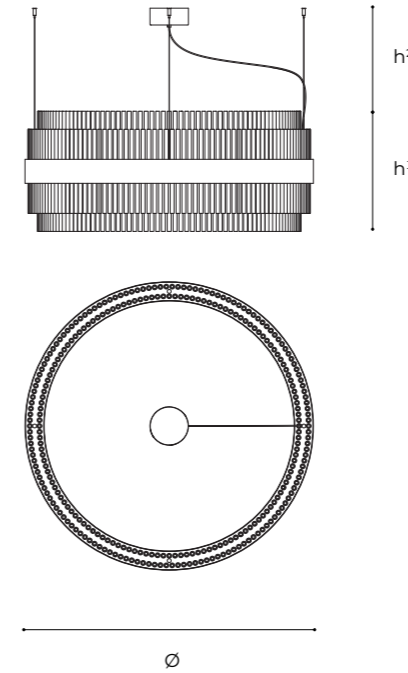

768/S120

Ø 120 . h^1 50 . h^2 10-100
 Ø 47" . h^1 20" . h^2 4"-39"
 130w Module Led - 13500lm
 CRI>90 - 3000K

Finishes:



Certifications:

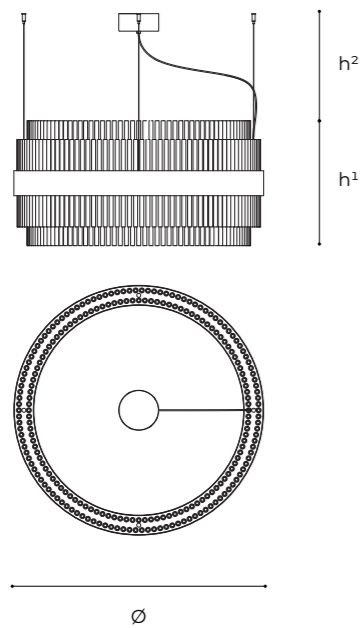

768/S100

Ø 100 . h^1 50 . h^2 10-100
 Ø 39" . h^1 20" . h^2 4"-39"
 120w Module Led - 11400lm
 CRI>90 - 3000K

Finishes:



Certifications:



PALETTE

design by **Italamp Studio**

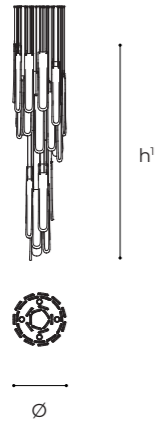

T785

Ø 54 cm · h1 220 cm
 Ø 22" · h1 87"
 4 spotted 7W · 3000K · CRI>93

Finishes:

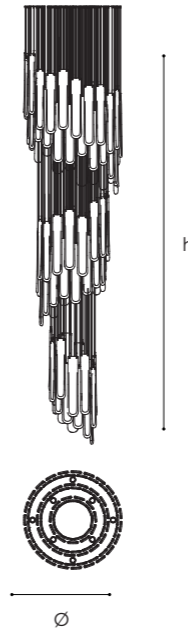

T785/B

Ø 98 cm · h1 389 cm
 Ø 39" · h1 154"
 8 spotted 7W · 3000K · CRI>93

Finishes:

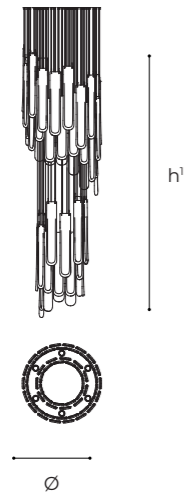

T785/A

Ø 75 cm · h1 253 cm
 Ø 30" · h1 100"
 6 spotted 7W · 3000K · CRI>93

Finishes:

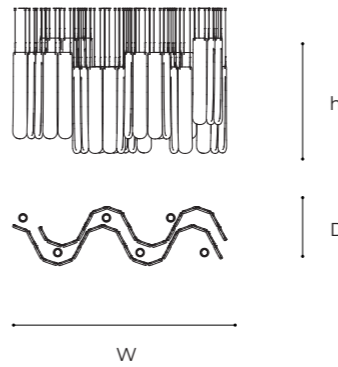

T785/C

W 150 cm · D 42 cm · h¹ 80 cm
 W 60" · D 17" · h¹ 32"
 6 spotted 7W · 3000K · CRI>93

Finishes:



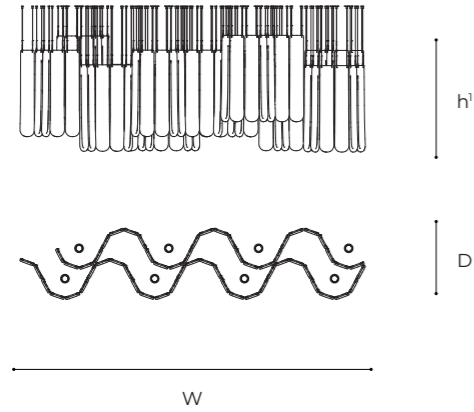

T785/D

W 240 cm · D 50 cm · h1 80 cm
 W 95" · D 20" · h1 32"
 8 spotted 7W · 3000K · CRI>93

Finishes:

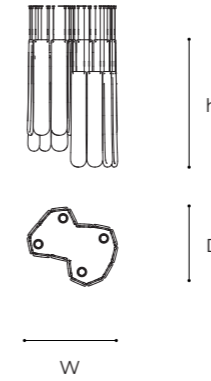

T785/F

W 57 cm · D 50 cm · h1 80 cm
 W 23" · D 20" · h1 32"
 4 spotted 7W · 3000K · CRI>93

Finishes:

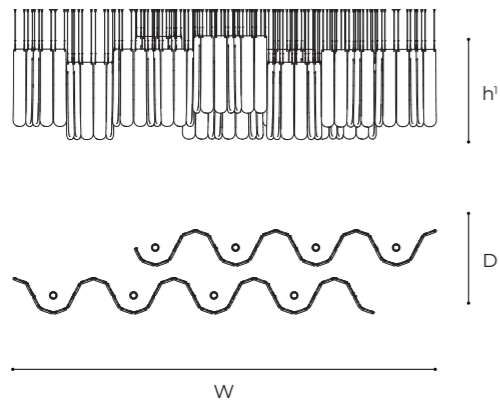

T785/E

W 330 cm · D 66 cm · h1 80 cm
 W 130" · D 26" · h1 32"
 8 spotted 10W · 3000K · CRI>93

Finishes:

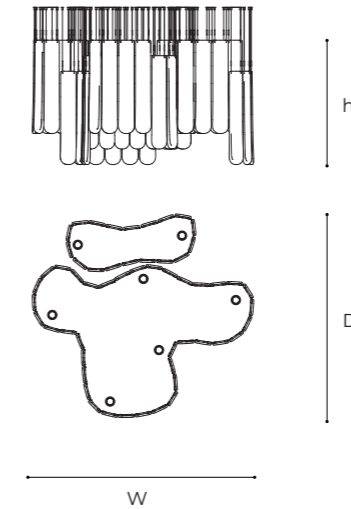

T785/G

W 143 cm · D 132 cm · h1 80 cm
 W 57" · D 52" · h1 32"
 7 spotted 7W · 3000K · CRI>93

Finishes:



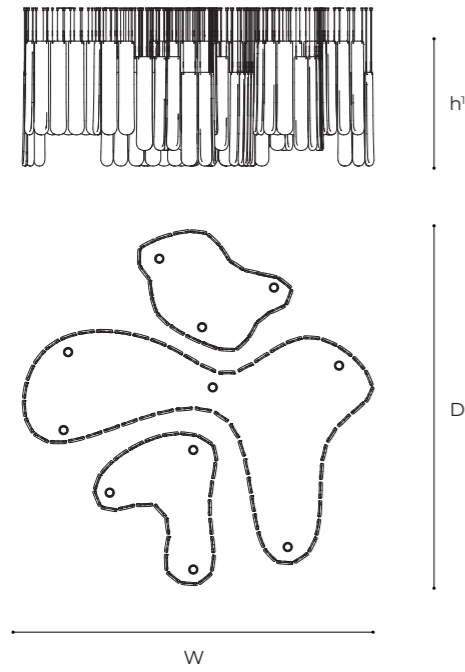

T785/H

W 226 cm · D 228 cm · h1 80 cm
 W 89" · D 90" · h1 32"
 11 spotted 7W · 3000K · CRI>93

Finishes:

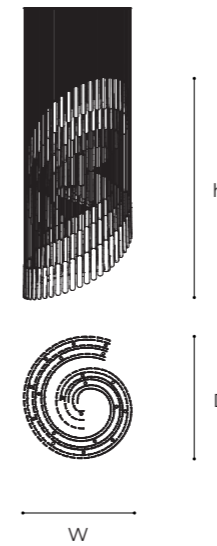

T785/J

W 206 cm · D 233 cm · h1 420 cm
 W 82" · D 92" · h1 167"
 20 spotted 10W · 3000K · CRI>93

Finishes:

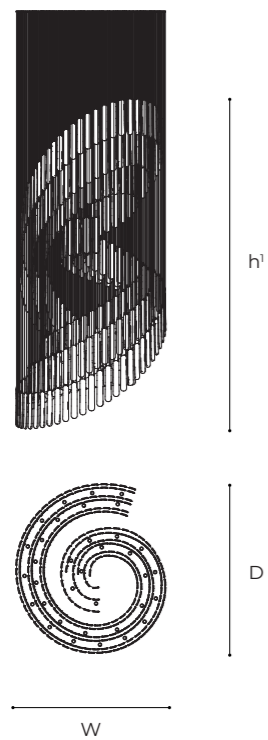

T785/I

W 250 cm · D 284 cm · h1 552 cm
 W 99" · D 112" · h1 218"
 35 spotted 10W · 3000K · CRI>93

Finishes:



Ogni prodotto Italamp è corredato di una documentazione contenente tra l'altro il certificato di autenticità e la scheda di collaudo. In caso di reclamo il cliente dovrà sempre fornire copia della scheda.

Sulla scheda sono contenute anche le istruzioni per un corretto montaggio dell'articolo.

Italamp non risponde per eventuali danni a persone o cose causati da una non corretta installazione dei propri apparecchi di illuminazione, da un uso di lampadine non conformi e dalla modificazione delle caratteristiche tecnico costruttive.

La ditta si riserva di apportare ai modelli ogni modifica estetica e tecnica che a suo insindacabile giudizio ritenga necessaria.

Il marchio **CE** è un marchio europeo di garanzia che certifica la qualità del prodotto e la sua rispondenza ai parametri di sicurezza previsti dalle normative CEE.

Italamp può fornire per la quasi totalità dei suoi articoli la certificazione con marchio UL. In tutto il mondo UL testa prodotti secondo i requisiti di sicurezza statunitensi per un accesso sicuro ovunque nel Nord America.

UNI EN ISO 9001/2015 certifica in maniera stabile l'alta qualità e la grande affidabilità di tutti i processi produttivi aziendali della produzione Italamp.

Italamp è un marchio registrato.

ATTENZIONE: I colori visualizzati, per noti motivi tecnici, sono indicativi e possono differire dall'originale: la reazione dei colori, vetri, texture, vernici e metalli varia a seconda dello spessore e delle dimensioni complessive del prodotto ma soprattutto della luce che batte sulla superficie complessiva. ITALAMP si riserva il diritto di apportare ai prodotti le modifiche che riterrà più opportune, in qualsiasi momento e senza preavviso.

Tutti i nostri modelli sono depositati e quindi coperti da brevetto.

Questo catalogo è tutelato dalla legge sui diritti d'autore (legge 22/4/1941 n°633 e dalla legge 14/12/1942 n°1485).

È vietata ogni riproduzione anche parziale dello stesso.

Each item is equipped with its own documentation including

a certificate of authenticity and a card with instructions for quality control inspections. In case of complaint the customer should send us a copy of this card, which also contains instructions for correct assembling of the fixture.

Italamp is not liable for incidental injuries or damage to people or things due to: incorrect installation of the fixtures, use of not suitable bulbs, modification of the original technical features of the items.

The company has the right to modify any model for both aesthetic and technical features when necessary, according to Italam's unquestionable judgement.

The **CE** label is a European guaranteed mark.

It certifies product quality and its compliance with the safety standards stated by EEC regulations.

Italamp can provide for most of its products the UL certification. Worldwide, UL tests products according to U.S. safety requirements for secure access anywhere in north U.S.

UNI EN ISO 9001/2015 steadily certifies the high quality and the great reliability of all Italam production processes.

Italamp is a registered trademark.

WARNING: The colors displayed, for known technical reasons, are indicative and may differ from the original: the reaction of colors, glass, textures, lacquers and metals varies depending on the thickness and overall size of the product but especially the light that beats on the overall surface.

ITALAMP reserves the right to make any changes to the products it deems most appropriate, at any time and without notice.

All our items are registered and covered by patent.

This catalogue is copyrighted and protected by the Italian law (22/4/1941 n°633 and 14/12/1942 n°1485).

Any reproduction of this catalogue is strictly forbidden.

Produced by:

Italamp s.r.l. All right reserved

No part of this publication may be reproduced or transmitted in any form or by any means, electronic or mechanical, including photocopying, recording, screen shooting or any information storage and retrieval system, without permission in writing from publisher.

project director and graphic content:

ITALAMP STUDIO

photo:

PHOTO DESIGN

color separation:

PUNTO 3 s.r.l.

ITALAMP S.R.L.
All right reserved
via Fermi, 8
35010 CADONEGHE . PD. ITALY
t. +39 049 8870442
info@italamp.com
italamp.com